

## CeilingMount1500

### Commercial Air Purification System



Designed for large spaces with solid ceilings, the CeilingMount1500 is ideal for demanding environments. With two finishes available, the CeilingMount1500 also features a front access panel for easy filter maintenance.

Dimensions	Noise Level	Weight	CFM	Finish	Speeds
35.375" L x 25.5" W x 17.625" H	5' - Low: 65 db, High 70 db	125 lbs.	1250 CFM	Black and oak	Dual speed
Horsepower	Volts	Watts	Amps	Misc.	
1 hp	120 V	744 W	6.2 A		

### DIMENSIONAL DRAWINGS

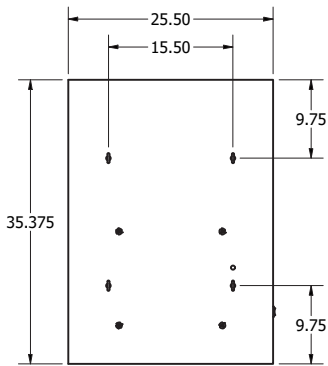

Top

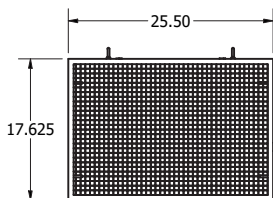
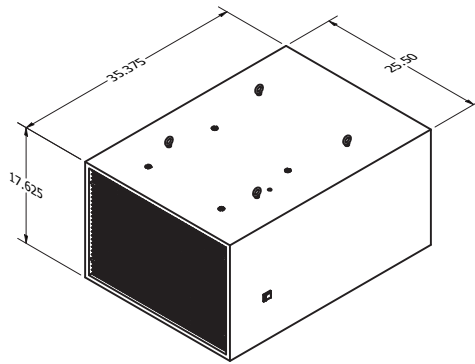

Front

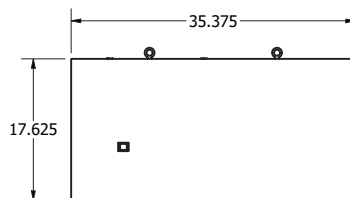

Side

#### STANDARD FILTERS

The CeilingMount1500 comes with a one-year supply of standard filters

- 12" HEPA Filter
- Carbon Pads
- Pre-Filters

#### ADDITIONAL FILTERS

The following filters can be added to the CeilingMount1500 for additional filtering in highly saturated areas

- 6" Carbon V-Bank