

MaxMount1500

Commercial Air Purification System

When clean air is paramount, look no further than the MaxMount1500. Housed in 18-gauge steel, the MaxMount1500 can be installed in a variety of places including above a ceiling, below a floor or in a crawl space. The powerful airflow works with a CFM of 1250 and has the option of high or low speed, which can be easily changed with the click of a button. MatrixAir's Triple Filtering System means quiet, safe contaminant removal for any environment.

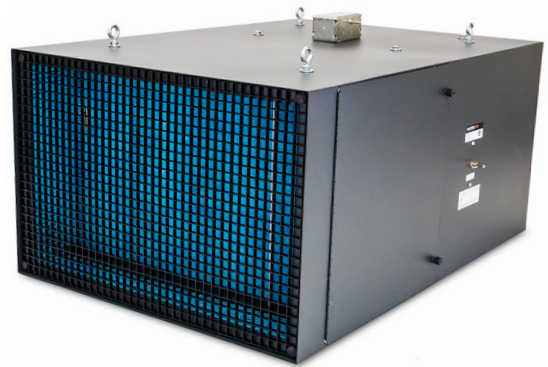

Dimensions	Noise Level	Weight	CFM	Finish	Speeds
36"L x 24.75"W x 17"H	5' – Low: 65 db, High 68 db	125 lbs.	1250 CFM	18 gauge steel	Dual speed
Horsepower	Volts	Watts	Amps	Misc.	
½ hp	120 V	1080 W	9 A	*3/4 hp, 9.6 A motor available	

DIMENSIONAL DRAWINGS

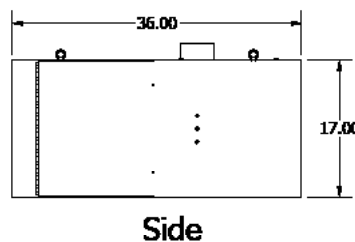
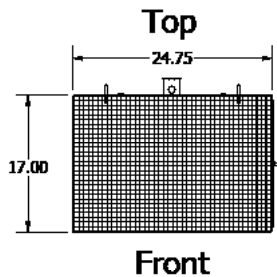
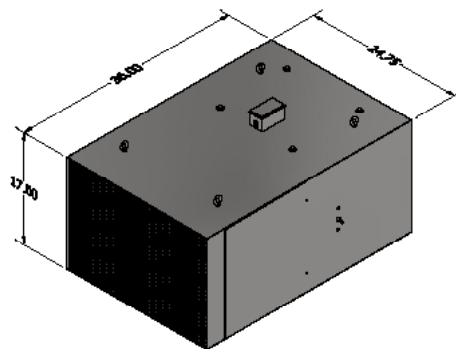
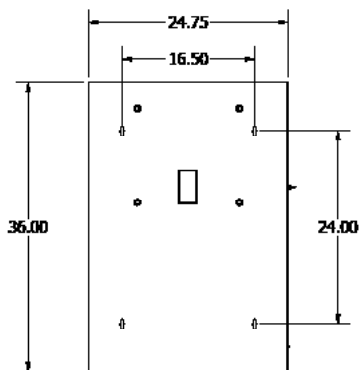

STANDARD FILTERS

The MaxMount1500 comes with a one-year supply of standard filters

- 12" HEPA Filter
- Carbon Pads
- Pre-Filters

ADDITIONAL FILTERS

The following filters can be added to the MaxMount1500 for additional filtering in highly saturated areas

- 6" Carbon V-Bank