

## MaxMount800

### Commercial Air Purification System

The MaxMount800 is designed to work in tough environments. Whether an office, machine shop, or any other large location requiring a moderate level of airflow, the MaxMount800 features a CFM of 850. With flexible installation options, the MaxMount800 can be installed nearly anywhere - above a ceiling, below a floor, in a crawl space or even a mechanical room! Powerful airflow combined with our exclusive Triple Filtering System means quiet, safe contaminant removal.

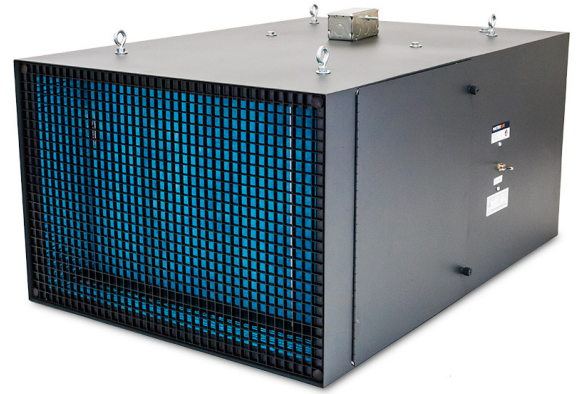

Dimensions	Noise Level	Weight	CFM	Finish	Speeds
36"L x 24.75"W x 17"H	5' - Low: 64 db, High 68 db	125 lbs.	850 CFM	18 gauge steel	Dual speed
Horsepower	Volts	Watts	Amps	Misc.	
1/4 hp	120 V	504 W	4.2 A	*3/4 hp, 9.6 A motor available	

### DIMENSIONAL DRAWINGS

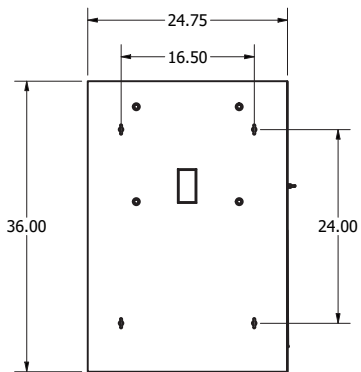

Top

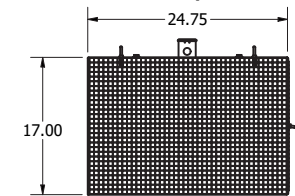
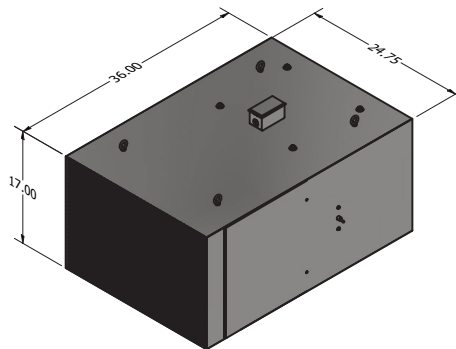

Front

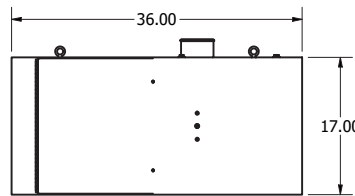

Side

#### STANDARD FILTERS

The MaxMount800 comes with a one-year supply of standard filters

- 12" Proprietary High Efficiency Filter
- Carbon Pads
- Pre-Filters

#### ADDITIONAL FILTERS

The following filters can be added to the MaxMount800 for additional filtering in highly saturated areas

- 6" Carbon V-Bank