

CeilingMount1000

Commercial Air Purification System

For 9-10' solid ceilings, MatrixAir's CeilingMount1000 delivers high powered air filtration in a small, easy to install package. Available in two finishes, the CeilingMount1000 offers an unobtrusive solution for clean air.



Dimensions	Noise Level	Weight	CFM	Finish	Speeds
35.375"L x 25.5"W x 13.6875"H	5' - Low: 64 db, High 68 db	100 lbs.	850 CFM	Black and oak	Dual speed
Horsepower	Volts	Watts	Amps	Misc.	
¼ hp	120 V	504 W	4.2 A		

DIMENSIONAL DRAWINGS

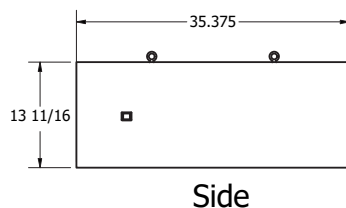
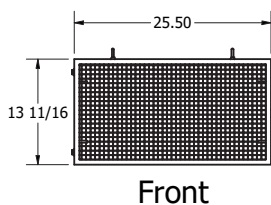
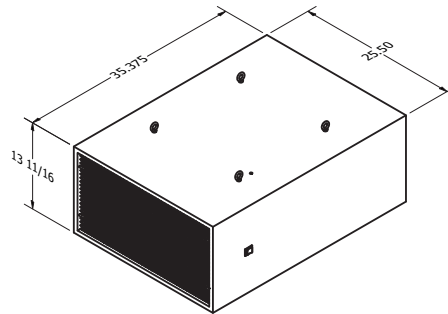
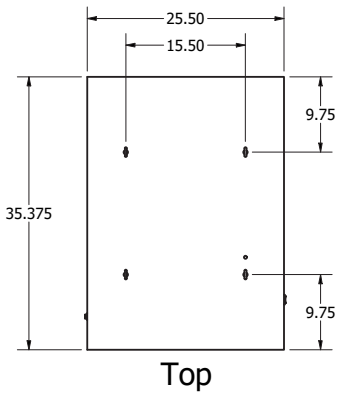

STANDARD FILTERS

The CeilingMount1000 comes with a one-year supply of standard filters

- 12" Proprietary High Efficiency Filter
- Carbon Pads
- Pre-Filters

ADDITIONAL FILTERS

The following filters can be added to the CeilingMount1000 for additional filtering in highly saturated areas

- 6" Carbon V-Bank