

MaxMount2000

Commercial Air Purification System

The MaxMount2000 is MatrixAir's largest and most powerful unit featuring a CFM of 1650. Despite the power, the MaxMount2000 features a small 16-gauge steel housing for flexible installation options. As with all units, the MaxMount2000 has been engineered with MatrixAir's Triple Filtering System for filtering contaminants large and small from any environment.



Dimensions	Noise Level	Weight	CFM	Finish	Speeds
36"L x 24.125"W x 24.125"H	5' - Low: 67 db, High 70 db	125 lbs.	1650 CFM	16 gauge steel	Dual speed
Horsepower	Volts	Watts	Amps	Misc.	
½ hp	120 V	1080 W	9 A	*3/4 hp, 9.6 A motor available	

DIMENSIONAL DRAWINGS

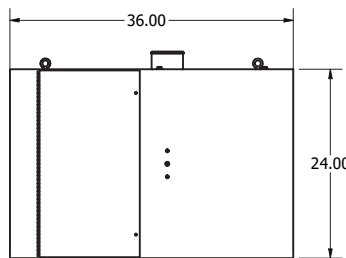
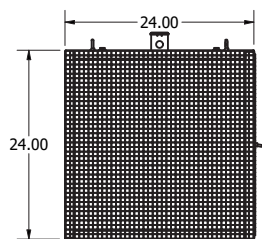
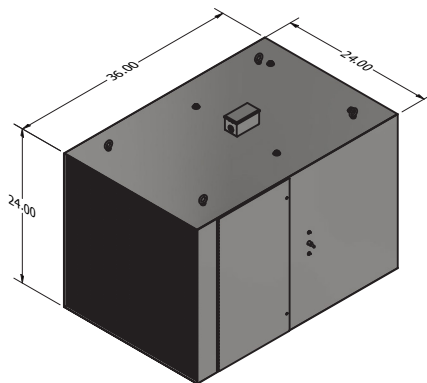
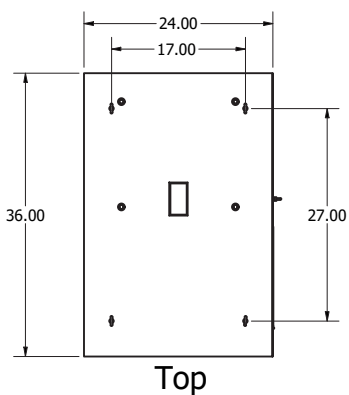

STANDARD FILTERS

The MaxMount2000 comes with a one-year supply of standard filters

- 12" Proprietary High Efficiency Filter
- Carbon Pads
- Pre-Filters

ADDITIONAL FILTERS

The following filters can be added to the MaxMount2000 for additional filtering in highly saturated areas

- 6" Carbon V-Bank